

"KZP3-RS" safety relay (45 mm)

- "Emergency stop" and "mobile guard monitoring" functions
- "CE" conforming product / BG approved
- Four input circuits for control device with one or two channels
- Safety via redundancy and self-checking
- Integrity check on control devices
- 3 "N/O" safety contacts with linked contacts - 6 A / 250 ~
- 1 "N/C" signalling contact
- Can be used to obtain level 4 according to NF.EN 954-1



Technical characteristics

Power supply

Power supply voltage	~ 24 V 50/60 Hz = 24 V max. ripple 10%
Operating range	-15% / +10% of Un for ~ -15% / +15% of Un for =
On/off indication	1 power supply voltage LED

Accuracy

Reset time	< 25 ms
Maximum response time on emergency stop	< 50 ms

Output specification

Type	Volt-free outputs
No. of safety circuits	3 "N/O" AgSnO ₂ contacts
No. of data circuits	1 "N/C" AgSnO ₂ contacts
Breaking capacity	1500 VA resistive
Max. current breaking capacity	6.82 A
Max. voltage breaking capacity	440 V~
Electrical life	10 ⁵ operations at 1500 VA resistive 5.10 ⁵ operations at 500 VA resistive
Mechanical life	10 ⁷ operations

Operation and use

Max. absorbed power	AC 3 VA / DC 3 W
On/off indication	1 internal relay status LED
Operating temperature	0°C to +50°C acc. to IEC 68-2-14
Storage temperature	-20°C to +70°C acc. to IEC 68-1/2
Internal voltage	24 V=
Dielectric strength	2.95 kV according to IEC 664-1
Resistance to tracking	Material group III

EMC immunity according to EN 50082-2

Rapid transients	2 kV directly acc. to IEC 1000.4.4 4 kV directly for the 230 V~ version 2 kV when coupled
Radiated electromagnetic field	30 V/m Level X acc. to IEC 1000.4.3 80 MHz to 1 GHz / 900 MHz (ENV 50140/204)
Electrostatic discharges	15 kV in the air acc. to IEC 1000.4.2
Shock waves	Level 3 according to IEC 1000.4.5 Common mode 4 kV for 230 V~ Common mode 2 kV for 24 V= and 24 V~
Radio frequencies in common mode	30 V rms Level X acc. to IEC 1000.4.6 150 kHz to 80 MHz (ENV 50141) according to IEC 1000.4.11
Drop-out / short breaks / microbreaks	Un-30% for 10 ms every 1 s Un-60% for 100 ms every 1 s according to IEC 61496-1/97 Un-100% for 10 ms every 100 ms*

* the device operates normally

** the device has not failed dangerously

Un-50% for 20 ms every 200 ms*

Un-50% for 500 ms every 5 s**

Casing

Material	Polycarbonate Self-extinguishing - UL94 class VO
Degree of protection	Casing : IP40 Terminal : IP20
Terminal capacity	2 X 1.5 mm ² multicore with ferrule 2 X 2.5 mm ² solid conductor
Weight	410 g

Type

KZP3-RS

Part number (and voltage)

24 V ~/=	85 100 536
----------	------------

Conformity

European "Machinery" Directive 89/392/EEC	●
French Decree 92/765-766-768	●
European "Usage" Directive 89/655/EEC	●
French Decree 93-40 / 93-41	●
IEC 61496-1	●
IEC 664-1	●
EN 50081-2	●
EN 50082-2	●
EN 60204-1	●
EN 292-1 and 2	●
EN 954-1	● Category 4
EN 418	●
EN 1088	●
UL 508	● UL
C22-2 No. 14-M91	● (C) UL
GS-ET-20	● BG

Connections

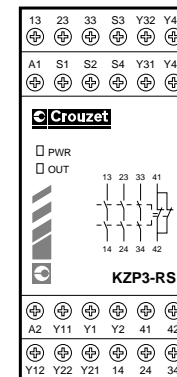

Key

A1-A2	: Power supply
Y11-Y12 and Y21-Y22	: Redundant inputs with differentiated voltage for control devices
Y31-Y32 and Y41-Y42	: Redundant inputs with differentiated voltage for control devices
Y1-Y2	: Start / validation
S1-S2 and S3-S4	: Short-circuit protection on start / validation input
13-14/23-24/33-34	: "N/O" safety contacts
41-42	: "N/C" signalling contacts

To order, specify :

Standard products

1 Part number

Example : KZP3-RS safety relay : 85 100 536

Control devices :

The KZP3-RS is used to obtain and maintain a category 4 level of safety for an installation with two control devices (see wiring example).

Depending on the degree of safety required, KZP3-RS can receive the following components as inputs :

- emergency stop pushbuttons with two contacts (Y11-Y12 / Y21-Y22 and Y31-Y32 / Y41-Y42)
- position sensors with one or two contacts (Y11-Y12 / Y21-Y22 and Y31-Y32 / Y41-Y42)
- pushbutton for start or validation (Y1-Y2)

A positive break operation device must be used if a single contact is used.

To increase the degree of safety, one "N/C" auxiliary contact per power contactor is cabled in series with the start (or validation) pushbutton, to ensure self-checking in this part of the installation.

Control devices :

The KZP3-RS has three "N/O" safety contacts (13-14/23-24/33-34) and one "N/C" signalling contact (41-42). One or more control devices may be wired up to the breaking capacity of the safety contacts : 1500 VA. However, to limit internal heating in the KZP3-RS, it is advisable not to exceed 10 A thermal for all three contacts. The signalling contact cannot be used as a safety contact. The signalling contact can be wired on a PLC input or integrated into a fault signalling system.

Extending the number of contacts :

The number of contacts of the KZP3-XS can be extended and the breaking capacity thus increased. To do this, use the KZE3-XS (see page 11/20).

Examples of use

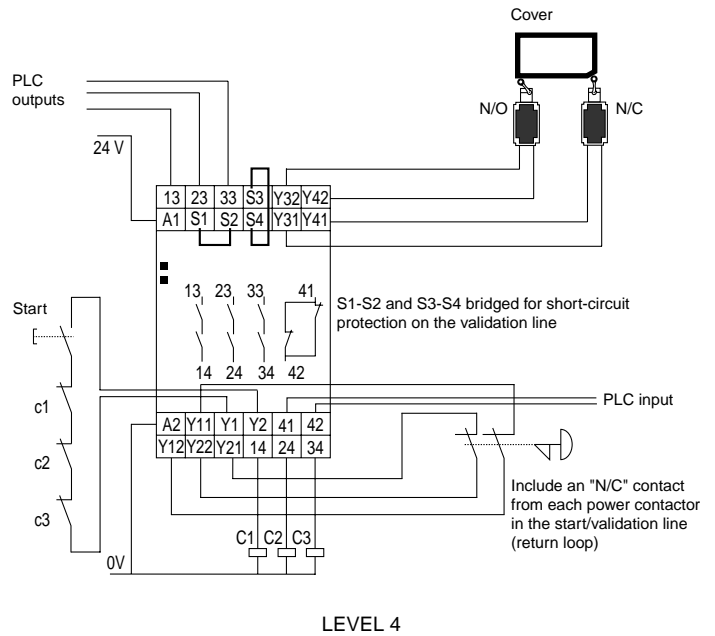
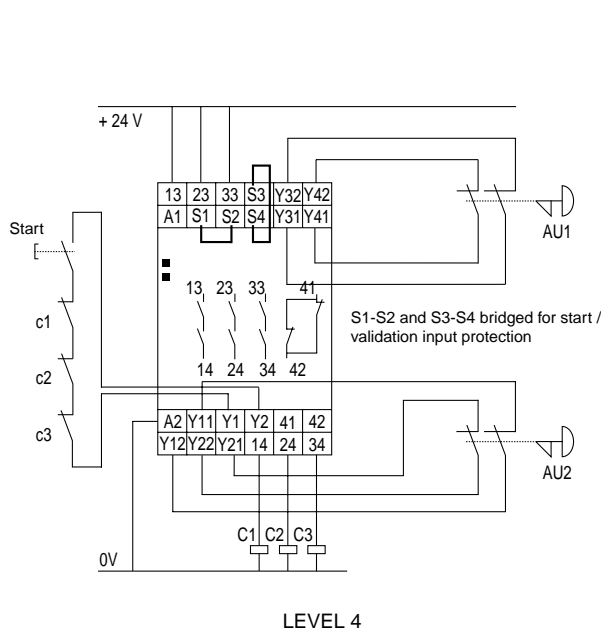

Dimensions

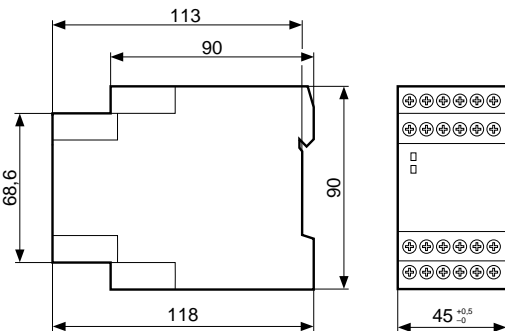

Mounting - Removing see page 11/7