

Pump control

→ 3-phase and single phase pump control relay - 35 mm

- Allows control and monitoring of single phase and 3-phase pumps
- Monitors phase sequence and phase failure
- Checks for undercurrent to protect against running dry
- Checks for overcurrent to protect against overload
- Digital inputs for operation control logic
- True RMS current measurement



HPC

Part numbers

Type	Measurement ranges	Nominal voltage (V)	Code
HPC	1 A → 10 A in DC	208 → 480 V ~ 3-phase 230 V ~ monophasé	84874200

Product adaptations



- Customisable colours and labels
- Fixed or adjustable time delay
- Fixed threshold in the generic range

Accessories

Description	Code
Removable sealable cover for 35 mm casing	84800001

General characteristics

Supply

Supply voltage Un	208 V → 480 V ~ 3-phase * 230 V ~ monophasé
Voltage supply tolerance	-12% / +10%
Operating range	183 → 528 V ~
~ supply voltage frequency	50/60 Hz ± 10%
Galvanic isolation of power supply/measurement	No
Power consumption at Un	5 VA in ~
Immunity from micro power cuts	500 ms

Inputs and measuring circuit

Measurement ranges	1 → 10 A ~ E1-L2: 1 → 10 A
Input resistance	E1-L2: 0.01 Ω
Permanent overload at 25°C	E1-L2: 11 A
Pulse overload < 1 sec at 25°C	E1-L2: 50 A
Frequency of measured signal	50 / 60 Hz: ± 10%
Max. measuring cycle time	150 ms/True RMS measurement
Adjustment of upper threshold	0.1 → 10 A
Adjustment of lower threshold	0.1 → 10 A
Fixed hysteresis	5% of displayed threshold
Display precision	±10% of full scale
Repetition accuracy with constant parameters	± 0.5%
Measuring error with voltage drift	< ± 1% across the whole range
Measuring error with temperature drift	± 0.05% / °C

Timing

Delays on power up (Ti)	1 → 60 s (0, + 10%)
Delay on threshold crossing	0.1 → 10 s (0, + 10%)
Repetition accuracy with constant parameters	± 1%
Reset time	2 s
Y2 minimum reset time	300 ms
Delay on pick-up	500 ms
Alarm on delay time max.	300 ms

Output

Type of output	1 single pole changeover relay
Type of contacts	No cadmium
Maximum breaking voltage	250 V ~
Max. breaking current	5 A ~
Min. breaking current	10 mA / 5 V ---
Electrical life (number of operations)	1 x 10 ⁶
Breaking capacity (resistive)	1250 VA ~
Maximum rate	360 operations/hour at full load
Operating categories acc. to IEC 60947-5-1	AC 12, AC 13, AC 14, AC 15, DC 12, DC 13
Mechanical life (operations)	DC 14, 30 x 10 ⁶

Insulation

Nominal insulation voltage IEC 60664-1	400 V
Insulation coordination (IEC 60664-1 / 60255-5)	Overvoltage category III: degree of pollution 3
Rated impulse withstand voltage IEC 60664-1/60255-5	4 kV (1.2 / 50 μs)
Dielectric strength IEC 60664-1/60255-5	2 kV ~ 50 Hz 1 min
Insulation resistance IEC 60664-1 / 60255-5	> 500 MΩ 500 V ---

Pump control

General characteristics

General characteristics	
Display power supply	Green LED
Display relay	Yellow LED
"Fault" indication	Yellow LED
Casing	35 mm
Mounting	On 35 mm symmetrical DIN rail, IEC/EN 60715
Mounting position	All positions
Material: enclosure plastic type VO to UL94 standard	Incandescent wire test according to IEC 60695-2-11 & NF EN 60695-2-11
Protection (IEC 60529)	Terminal block: IP 20 Casing: IP 30
Weight	100 g
Connecting capacity IEC 60947-1	Rigid: 1 x 4 ² - 2 x 2.5 ² mm ² 1 x 11 AWG - 2 x 14 AWG Flexible with ferrules: 1 x 2.5 ² - 2 x 1.5 ² mm ² 1 x 14 AWG - 2 x 16 AWG
Max. tightening torques IEC 60947-1	0.6 → 1 Nm / 5.3 → 8.8 Lbf.In
Operating temperature IEC 60068-2	-20 → +50°C
Storage temperature IEC 60068-2	-40 → +70°C
Humidity IEC 60068-2-30	2 x 24 hr cycle 95% RH max. without condensation 55°C
Vibrations according to IEC/EN60068-2-6	10 → 150 Hz, A = 0.035 mm
Shocks IEC 60068-2-6	5 g
Standards	
Marking	CE (LVD) 73/23/EEC - EMC 89/336/EEC
Product standard	NF EN 60255-6 / IEC 60255-6 / UL 508 / CSA C22.2 N°14
Electromagnetic compatibility	Immunity EN 61000-6-2/IEC 61000-6-2 Emission EN 61000-6-4/EN 61000-6-3 IEC 61000-6-4/IEC 61000-6-3 Emission EN 55022 class B
Certifications	UL, CSA, GL pending
Conformity with environmental directives	RoHS, WEEE
Comments	
	* 3-phase mains with earth

Principles

HPC

Overview

The pump controller can operate on a single phase or 3-phase network. It provides 3 functions in one unit:

- Checking current,
- Checking phase presence (in 3-phase mode),
- Checking phase sequence (in 3-phase mode).

It has two operating modes whose purposes is to control a pump based on two external signal inputs (Y1 Y2).

These two signals are controlled by volt-free contacts.

Faults are signalled via LEDs, distinguishing the origin of the fault.

Operating principle

Selecting the operating mode

A rotary switch on the front is used to select:

- single control mode,
- dual control mode,
- single-phase or 3-phase network.

The position of this selector switch is only taken into account when the unit is powered up.

If the switch position changes while the unit is operating, all the LEDs flash but the product continues to work normally with the mode selected on energisation prior to the change of position.

The LEDs return to their normal state if the switch is reset to its initial position defined before the last energisation.

HPC - Single control mode

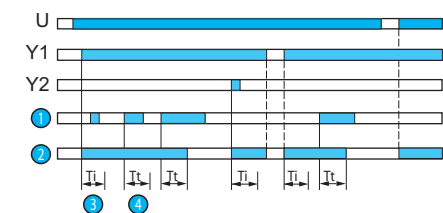

- 1 Current fault
- 2 Relay
- 3 Fault monitoring inhibit time on pump start-up (Ti)
- 4 Delay timing in case of fault (Tt)

This mode is for controlling a pump based on one external signal (Y1).

The relay output is closed when the signal is present at Y1 (contact closed).

After a fault the relay remains open (even if the current returns to normal) and the module can be reclosed in two different ways:

- By a reset: cutting of power supply,
- Or by a reset through pressing an external contact (pushbutton for example) entering the second control input (Y2).

Principles

HPC - Dual control mode

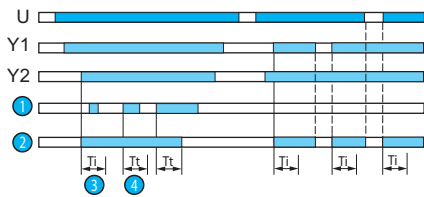

- ① Current fault
- ② Relay
- ③ Fault monitoring inhibit time on pump start-up (T_i)
- ④ Delay timing in case of fault (T_t)

HPC - Overcurrent control

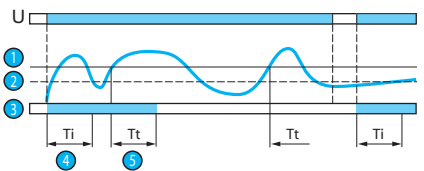

- ① Overcurrent
- ② Hysteresis
- ③ Relay
- ④ Fault monitoring inhibit time on pump start-up (T_i)
- ⑤ Delay timing in case of fault (T_t)

HPC - Undercurrent control

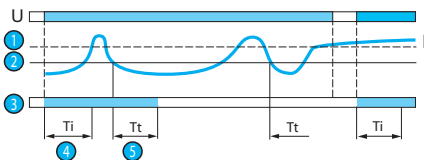

- ① Undercurrent
- ② Hysteresis
- ③ Relay
- ④ Fault monitoring inhibit time on pump start-up (T_i)
- ⑤ Delay timing in case of fault (T_t)

This mode is for controlling a pump based on two external signals (Y1 and Y2). The output relay closes when both input signals are present (Y1 and Y2 closed). It will open as soon as either of these two signals is absent.

If the controller is configured in single phase, it monitors the current drawn by the pump. If the controller is configured in 3-phase, it monitors current, phase sequence and phase failure. If a phase fault is detected, the output relay opens immediately. On energisation, the output relay cannot be closed if there is a phase fault or phase failure.

Current control

The under and overcurrent values are set by two independent potentiometers graduated from 1 to 10 A.

In case of a control error (low threshold higher than high threshold), the output relay opens and all the LEDs flash to signal the error.

If a current fault occurs (under or overcurrent) the relay opens if the fault persists beyond the preset threshold delay. When the current returns to a correct value, the output relay remains open. It can only be closed by a reset: either by de-energisation or by closing on external contact Y2 (in single control mode)

An inhibit delay (T_i) on energisation allows current peaks due to start-up of the motor to be disregarded.

Pump control

Dimensions (mm)

HPC

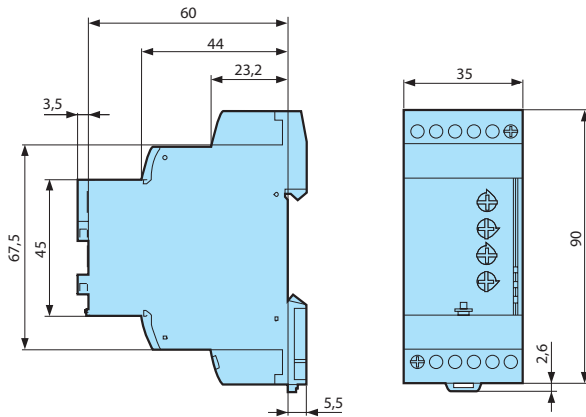

Connections

3 ph < 10 A

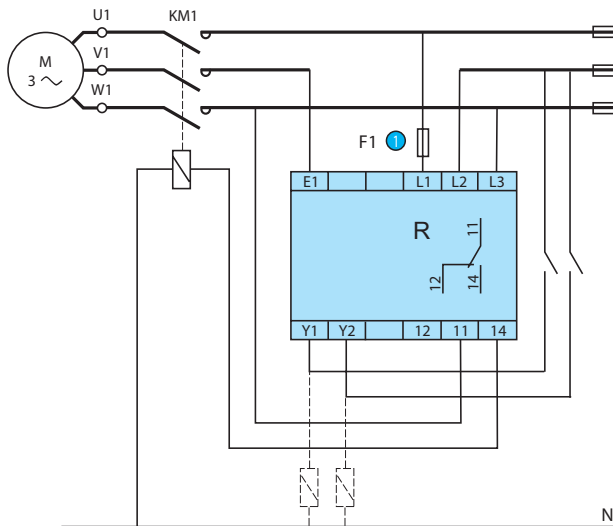

① 100 mA fast-blow fuse or cut-out

1 ph ~ 230 V < 10 A

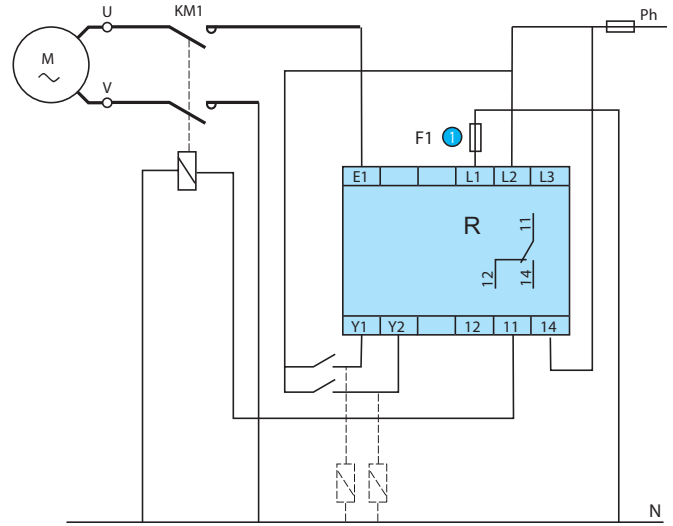

① 100 mA fast-blow fuse or cut-out

